

Micro-PET NEMA-NU4 Image Quality Mouse Phantom

QRM-MicroPET-IQ

According to the NEMA standard NU 4-2008, this phantom provides the opportunity to evaluate the performance of Micro-PET systems.

The NEMA NU 4-2008 standard proposes a standardized methodology for evaluating the performance of positron emission tomographs (PET) designed for small animal imaging.

The phantom is made from PMMA and offers a large cavity (D = 30 mm) on the first half of the cylinder fillable with isotope (hot region).

The large cavity houses two smaller cavities separated from that volume to be filled with water and air (cold regions) (see view A-A in the drawing on the right hand side).

The second half of the cylinder houses five smaller cavities (D = 1, 2, 3, 4 and 5 mm), radially aligned around the phantom length axis (see view B-B in the drawing on the right hand side) and provides an interconnection to the first half filled with isotope (hot region).

Specifications

- Base material PMMA
- Outer diameter 33.5 mm
- Length 63 mm
- two separate cavities (D = 8/10 mm) to be filled with water and air (cold region)
- 5 cavities (D = 1, 2, 3, 4 and 5 mm) radially orientated, to be filled with isotope (hot region).

The NEMA NU 4-2008 report is not part of the phantom described here. It has to be ordered separately at www.nema.org!

References:

- [1] Performance Measurements for Small Animal Positron Emission Tomographs;
NEMA Standards Publication NU 4-2008



Micro-PET IQ Phantom
(according to NEMA NU 4-2008)

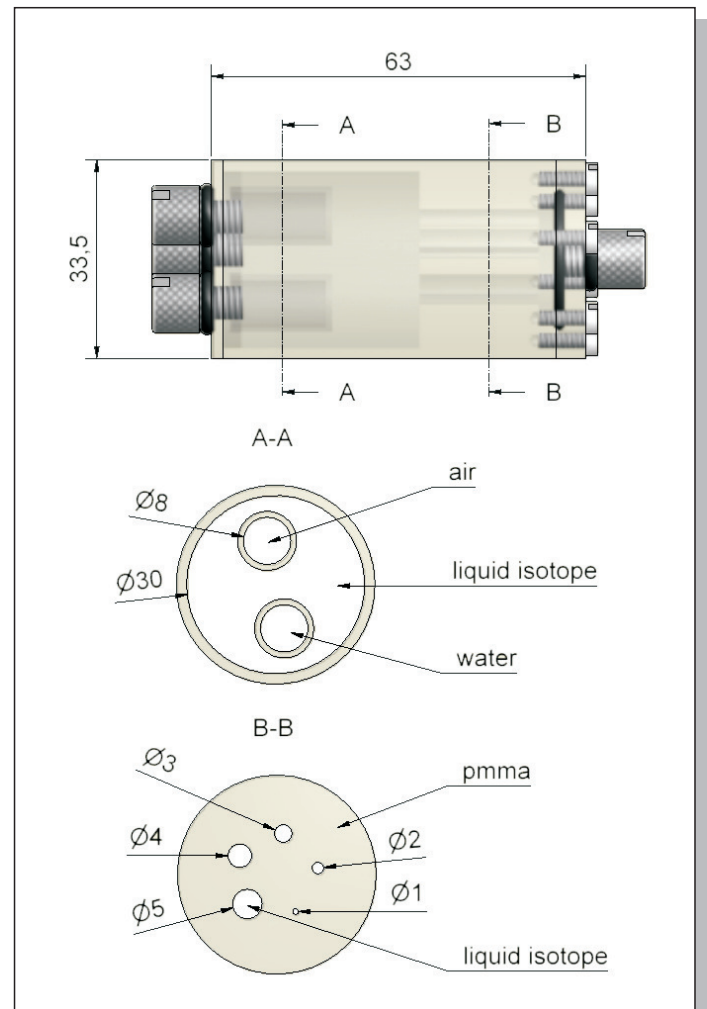

Dimensions of the phantom (in mm)